



Bluebird Restoration Association of Wisconsin

Information Packet:
Attracting Eastern Bluebirds &
other cavity nesters

5th
Edition

Edited by Patrick Ready (BRAW Editor)

Life cycle of the Eastern Bluebird (*Sialia sialis*) by Patrick Ready.



Pair select box and female builds the nest.



Within a week or two
3-5 eggs are usually
laid in the nest.



The male stands guard.



After 13-14 days of
incubation the
chicks hatch.



After 16-22 days old the chicks
are ready to fledge.



The chicks grow
quickly being fed
by both parents.



Bluebird Restoration Association of Wisconsin, Inc. has come a long way since its inception in 1986 with its understanding about how to effectively manage Eastern Bluebirds. This booklet pulls together the collective experiences of people who work especially for the interests of bluebirds, particularly those persons who record and summarize their nest box data and whom we term “monitors.” BRAW’s handling and interpretation of monitor data is done through data entry and computer analysis.

BRAW is the first to admit that not all experiences with bluebirds is typical of them throughout the state. However, most of our knowledge appears to be true regardless of where we encounter them. But bluebird management can be restricted by climate, geography, and habitat. The presence or absence of one or more natural enemies of bluebirds can alter results or even be a disaster. Nest box design, how a nest box is mounted on a post, and the spacing of boxes can profoundly affect what happens on a bluebird trail.

It is our hope that this **Informational Packet** produced by the Bluebird Restoration Association of Wisconsin, Inc. will bring you better understanding about how to succeed in helping this bird “with the sky on its back.”

The Bluebird Restoration Association of Wisconsin, Inc. (BRAW) is a nonprofit organization incorporated under the Laws of the State of Wisconsin. The **purpose and mission** of BRAW is to increase the production of the Eastern Bluebird and other native cavity-nesting song birds through a coordinated, statewide nest box construction and monitoring program. BRAW seeks to expand public knowledge and enthusiasm for the Eastern Bluebird so that a growing number of people will have the desire to aid cavity nesters and have the knowledge about how to best accomplish this in their own communities. BRAW coordinates its cavity-nesting recovery program through a network of volunteer **County Coordinators**, workshops, meetings, and its official **Wisconsin Bluebird** newsletter and our website: www.braw.org.

When BRAW was organized in 1986, it was estimated that the Eastern Bluebird population *in its historic range* had declined by 90 percent during the preceding 50 years due to changes in agriculture practices, competition from the House (English) Sparrow and European Starling, severe weather in its central and southern winter ranges, and the loss of nest sites, such as tree cavities and hollow wooden fence posts.

A few far-sighted individuals and local organizations that took note of the plight of bluebirds in their respective communities had helped bluebirds and other cavity nesters during those bleak years. Much experimentation was done to develop nest boxes. Some of those efforts were more successful than others. Bluebird “trails” consisting of a few or many bluebird nest boxes were established by some persons. Special care of nest boxes (monitoring) was begun by more knowledgeable bluebirders. A few individuals kept records by documenting bluebird nesting success and events on their trails.

BRAW works to bring to light the efforts of Wisconsin citizens who had been helping bluebirds in the past and those who have recently joined their ranks. Since 1996, BRAW has entered monitors’ data into a computer database and as a result, through computer analysis of the data, we are gaining better insights; and nest box designs affect bluebird population dynamics.

Through workshops, the Annual State Convention, and publication of research findings in the **Wisconsin Bluebird** newsletter, BRAW shares successful production techniques while hopefully avoiding some of the mistakes painfully learned by earlier bluebird enthusiasts.

County Coordinators are the “grassroots” of Wisconsin’s Eastern Bluebird restoration program. County Coordinators often conduct local workshops each year that are usually held in late winter and early spring. BRAW’s County Coordinators distribute literature, are sources for nest box construction plans, answer questions, and otherwise serve as knowledgeable persons to help individuals, clubs, and organizations effectively aid bluebirds and other cavity nesting birds. The County Coordinators assist interested persons in becoming members of BRAW.

BRAW members provide the financial base for the publication of the quarterly newsletter, **Wisconsin Bluebird**. The newsletter reports monitors’ data, data interpretations, various readers’ experiences, and cavity nesters. In addition the newsletter covers how to recognize good habitat, why and how to monitor a bluebird trail, spotting bluebirds’ natural enemies, defending bluebirds against them, and identifying nest failures and solutions. Read about the impact and significance of other bird species that may nest in bluebird nest boxes, the names and addresses of County Coordinators and BRAW, Inc. officers and directors.

BRAW, Inc. maintains liaisons with the Department of Natural Resources’ Bureau of Endangered Resources, the UW-Stevens Point, the North American Bluebird Society (NABS) and the Wisconsin Society for Ornithology.

We invite you to join us and be a part of the bluebird conservation movement in Wisconsin.

Visit our web site at: www.braw.org

GUIDELINES FOR SUCCESSFUL MONITORING OF EASTERN BLUEBIRD NEST BOXES



Pat Ready

This monitoring guide is dedicated to the hundreds of nest box monitors that have collected data for BRAW for over 30 years. It is because of their careful collection of data and responsible reporting that it has been made possible.

The Bluebird Restoration Association of Wisconsin has been around for over 30 years. Many ideas have come and gone over that time period. Some were bad and forgotten. Some were tried and true. This resource guide contains the best information we know of that will help you attract Eastern Bluebirds whether you have a single box in your yard or have several boxes comprising a bluebird trail.

Many factors affect the success of your desire to get bluebirds and have them return year after year. One of them is the weather. It is obvious that we will never control the weather. But it is not only the weather in Wisconsin that influences bluebird reproduction in the state. Severe weather down south where many of our resident bluebirds spend winter can take a toll on their population. In particular ice storms can cover their food sources for several days causing many birds to starve.

No other cavity nesting songbird is

subject to this reproductive influence by the weather. Black-capped Chickadees do not migrate much and both Tree Swallows and House Wrens migrate far enough south that weather does not influence their overwintering populations much. Moreover, Tree Swallows (3-4 weeks later) and House Wrens (5-6 weeks later) do not start nesting until much later in the season and are not as subject to harsh weather effects on reproduction as are bluebirds.

In spite of the good news about bluebird populations in Wisconsin and the U.S., this species continues to be vulnerable to weather and competition from other cavity nesting species. A continuation of conservation efforts is not only desirable, it is essential if we are going to produce healthy numbers of this charismatic species.

Common Myths Associated With Bluebird Monitoring.

There are several myths that monitors must dispel in order to reach a high productive output for their boxes:

1) Moderate disturbances will cause bluebirds (and other cavity nesting songbirds) to abandon their nests.

This is so untrue. This myth, very common in the general public, has been used forever by parents and others to keep children from vandalizing nests. It may serve a good function from that standpoint, but beyond that goal, the idea is worthless.

It should first be noted that perching birds (= passerines) can smell but, "residual human scent on eggs and nest does not deter the parental instincts of passerines (Gill 2007)". Their sensory existence is mainly limited to sight and hearing. When one opens a nest box, therefore, and handles the eggs or young, or the adults themselves, the birds are not noticeably influenced by smells from the monitor.

In fact, bird banders have captured both adults and young in nests for decades, taken them out to band them, held them firmly to affix the band and then released (adults) or replaced juve-

niles in the nests—all with only rare mishaps. And bluebird monitors don't come close to traumatizing juveniles & adults in this way.

2) When you place a nest box, you are placing it in a permanent position, never to move it again.

Nothing could be further from the truth. No nest box on any bluebird trail should be considered permanent unless it is attracting bluebirds! To do otherwise is to focus on your ego that is saying: "this place will be absolutely ideal for bluebirds". Well, I am sorry if bluebirds don't build in your house, but they are saying, "sorry, monitor, I don't like where you placed the box—I can't raise young in these conditions". Don't you owe it to them to put it in a place where they can nest successfully?

By moving any boxes that have had no bluebird nests in them by the end of April the 2nd season the boxes are in place, you have essentially given them two seasons to attract bluebirds, but can then place them in a new position that still has a 50:50 chance to attract a pair for the remainder of the 2nd season. Of course, if another songbird has already occupied your nest box by the end of April in the 2nd year, the songbird should be left to complete its reproductive cycle

3) Noise will prevent successful nesting in bluebirds.

To me, it was surprising to find that bluebirds tolerate high levels of noise. The first insight I got about this fact was placement of a nest box in a park along a heavily traveled street on the west edge of Plover, WI. This box has been in place for ten years and has successfully produced broods all ten years and successful double broods in most of those years.

What was most important was the habitat I selected. It consisted of a highway with a swath of vegetation of about 50' kept cut low (made it ideal for ease of insect observation), 20-30' high electrical wires overhead for perch hunting, short trees in front of the boxes for adults to perch on prior to entering the box with food and for

young to fly to when they fledged, and railroad tracks with short grass hunting sites on both sides of the track. In spite of the noise levels, an excellent and productive habitat for bluebirds.

4) One should not put boxes next to roadways for fear of bluebirds being killed by passing cars.

Moderately traveled roads (with good bluebird habitat) provide a great opportunity to raise successful broods and are safe for monitoring. Heavily traveled roads can be outstanding for raising bluebirds but hazardous to stop along.

5) One has to monitor nest boxes only once every two weeks or a month.

When one assumes the responsibility for monitoring a nest box, you assume the responsibility to do what you can, to see that the natural cycle of the songbird is completed without interference from humans or other predators. Monitoring once per week assures: 1) accurate collection of data 2) nests and/or eggs will be removed from inactive boxes 3) removal of wet nests or wet nests with eggs or chicks can be replaced with dry nests 4) dying chicks can be removed and fostered into nests with healthy young 5) finding and controlling acute problems such as black fly infestations 6) fixing nest boxes, posts or guards that might have been damaged and that are threatening the safety of the songbirds in question and 7) locating and/or reporting any vandalism to your boxes.

Natural History Information for Cavity Nesting Songbirds

Bluebirds face competition from other cavity nesting songbirds such as House Sparrows, Tree Swallows, Black-capped Chickadees and House Wrens.

In late March & early April, only sparrows and chickadees compete with bluebirds for nest boxes, as all start nesting about the same time (sparrows nest before bluebirds, bluebirds nest before chickadees). If one places nest boxes 100+ feet in the open, away from wooded edges, occupancy by chickadees is normally not a problem. Likewise, if you place your nest boxes some distance away from cattle and other livestock (200+ yards) or do not



Shari Kastner

place your boxes in suburban neighborhoods, occupancy by sparrows is minimal.

Bluebirds have a “wing up” on Tree Swallows in that they will start building nests 3-4 weeks before they do. As our winters have shortened due to global warming, swallows are narrowing that gap because they are migrating back from the Gulf Coast earlier.

You can prevent competition from House Wrens. First of all, if one places a nest box 100'+ away from short & dense, brushy vegetation, wrens usually do not build in those boxes and if they do so, build dummy nests. Secondly, wrens migrate back to WI even later than swallows. Since they do not even start nesting until mid-May, nearly 100% of nest-seeking bluebirds have selected boxes by then. Wrens are almost never a competitor in the 1st nesting cycle for bluebirds, but can become a major competitor in the 2nd or 3rd nesting cycles. It's best to avoid putting boxes near dense trees or shrubs where wrens like to hang out.

What kind of nest box should I use for a bluebird trail?

Bluebirds will nest in almost any box type if it's placed in the right habitat for them. In their natural environment, bluebirds largely occupy abandoned woodpecker holes. Therefore, boxes that simulate these holes work best. Shallow nest boxes with floors that are only 4-5" below the bottom of the oval

hole and with an interior platform of 4"x 4" or 4"x5", fledge the most bluebirds. BRAW has found three designs it prefers for attracting bluebirds and getting the best production of fledglings. The NABS-Style box, The Simple Box and the Peterson box are all good designs that BRAW recommends. (See box plans in the back of this guide.)

Monitoring Instructions.

1) Terminology

Sprigs: Pieces of grass put into a box by a male to entice a female to the box

Partial Nest: Any nest construction with grasses placed in a circle or covering the nest platform until a cup is formed in the nest

Complete Nest: Any nest with a deep cup

Complete Nest, Ready for Eggs: A deep cup with grasses tightly packed by the body of the female

Clutch: Total eggs in nest

Brood: Group of young birds in the nest

Broody: Word to explain why a female does not want to leave the clutch when the box is opened

Double Brood Box: Boxes that have fledged two broods

Triple Brood Box: Boxes that have fledged three broods

Fledged or Fledgeout: The process of young permanently leaving the nest

Fledglings: Young that have permanently flown from the nest.

Juveniles: Young that are living outside the nest; first stage of adulthood

Juvenile Assisted Feeding: Juveniles from the first brood who are assisting in feeding the 2nd or 3rd broods or the juveniles from the 2nd brood who are assisting feeding in the 3rd brood.

Nest Box Year: A nest box that has been monitored for one season

Nestling (= hatchling, chick or young): Individual birds in the nest

EABL: Eastern Bluebird

TRES: Tree Swallow

HOWR: House Wren

BCCH: Black-capped Chickadee

HOSP: House Sparrow

2) Forms to use.

Use individual sheets for each nest box (BRAW Form 22 - download at www.braw.org). When you use Form 22, you are expected to determine

the age of the young in the nest box to assure that you take caution as they age, in order to keep them from jumping out of the nest box (see photographic chick aging sequence of Dr. Jack Bartholomai on back cover). If you monitor the nest boxes once every 6-8 days (1 week average), it is usually pretty easy to determine the age of the young, accurate to within a day.

At the end of the season use the information you gathered and report it to BRAW for their Annual Data Report printed in the *Wisconsin Bluebird* newsletter. Use the BRAW EZ Summary Form (Pg. 9) and mail it or email it to BRAW following the instructions on the form. **You can also go to www.braw.org and enter your data online and you will receive an email confirming we received it.**

3) Approaching & opening the nest box.

Monitor boxes once/week. Experience has shown that production of bluebirds improves if you visit one or more times/week. For example, if there is an extreme weather event and a nest gets wet, the eggs/birds can survive for only a few days. If you monitor the boxes only once every two weeks, you assure that the eggs/young will die under these circumstances. By visiting every week, you could build a dry nest and save the eggs/young (see below). Also, weekly monitoring helps you determine if the nest is active or not. Destroying inactive nests increases productivity.

As you approach the nest box, make a loud pishing or clapping noise from 10-20' away. Pishing is commonly used by birdwatch-

ers and involves making a shhhhhh sound with an explosive "p" sound preceding it (one continuous sound). If the hen does not flush from the nest, go to the back of the box and make loud tapping noises on it.

By using these techniques, you should be able to get an accurate count of eggs and young, important data for BRAW.

4) Counting eggs & nestlings.

After you have flushed the hen from the nest, you are then ready to count the eggs and/or nestlings.

Counting eggs:

A complete clutch (= total) is 4-5 light blue eggs. In unusual cases, probably associated with exceptionally good habitat & feeding conditions, 6 eggs are laid.

When you look into the "hen-less" nest, pull back the cup edge and you will be able to see the eggs.

If it is a Tree Swallow nest, you must part the feathers to find the eggs. The eggs of chickadees are covered when the hen leaves the nest during egg laying, so carefully pull back the hair covering them to get a count. In some



Tom Koch

cases, it is best to "touch-count" the eggs. This technique allows you to count the eggs with minimal disturbance. Rarely, you will find a larger, brown-mottled egg in the nest that is likely to be that of a Brown-headed Cowbird. This bird is protected and the egg should be left in the nest to complete its natural cycle.

To help prevent this parasitism, reduce the size of your box opening.

Incubation takes 13-14 days in bluebirds (Erlich et al. 1988). The hen may delay initiation of incubation until the weather warms. This is why one should use the 19 day criteria before cracking open a sample egg to see if it is viable.

Counting nestlings:

Healthy nestlings that are hungry will naturally "gape" when you open the nest box. If they are sleepy or recently fed, they usually can be enticed to gape by making a light pishing, kissing or whistling sound. If neither of these efforts allow you to get an accurate count of the nestlings, simply pick up one or two of them and spread out the others. And, remember, smell is not a problem for cavity nesting songbirds.

Rearing chicks takes 15-21 days, depending on the time of year (spring is longer, summer shorter; Berger et al. 2001).

5) After the young have fledged, what do I do with the old nest?

Remove the nests from the boxes after the young have fledged. Scrape off all feces on the sides of the boxes, you do not have to wash out the inside of the box. For those that are com-

Reproductive landmarks of songbirds & House Sparrows In the Central Wisconsin area (2005 Data*)

Bird Species	Arrival Date	1st nest Built	1st egg Laid	1st Hatch	1st Fledge	Last Fledge	Length of Reproduction
EABL	24 Mar	1 Apr	10 Apr	30 Apr	20 May	10 Sept	163 days
BCCH	Resident	7 Apr	18 Apr	5 May	25 May	25 July	110 days
TRES	29 Mar	1 May	12 May	8 June	28 June	21 July	82 days
HOWR	20 Apr	15 May	23 May	20 June	20 July	2 Sept	107 days
HOSP	Resident	1 Apr	10 Apr	DNA	DNA	DNA	# 163 days

*In some cases, the actual dates may be off by a few days

Estimated only

pelled to more thoroughly clean out the box, however, use only water and a towel (no soap; windex spray bottles work well).

Remove the old nest from the area, place it in a plastic sack and dispose of it in the trash at home. While insects such as blow flies are rarely a problem for songbirds in our experience, there is only one reason to leave the nest in place, that of leaving the jewel wasp, a parasite on blowflies, in place to parasitize blowflies in the next nest (Berger et al. 2001). Since it has been our experience that blowflies are not injurious to bluebird nestlings and that old nests block nesting attempts by other bluebirds, we still recommend removing the old nests except in the situation that follows: The longer one has a trail in place, the more common are second (and third) nestings. This means that new nests will sometimes be started prior to removing the old nest. In that case, the new nest can be built so high that it makes the bluebirds more vulnerable to predation because they are so close to the opening. If the nest is sturdy enough, it is possible to lift it off of the old nest and remove the old nest from under it. In other instances, it is so flimsy that it is best to leave the old nest underneath the new one. It is not worth the risk of disturbing nest building and the abandonment of the box by the hen.

6) What should I do if nests remain incomplete, empty, or with unhatched eggs?

All songbirds are protected by the Migratory Bird Treaty Act of 1918. The Act states: “unless and except as permitted by regulations...it shall be unlawful at any time, by any means or in any manner to pursue, hunt, take, capture, kill...possess, offer for sale, sell, purchase, ship, export, import..., transport or cause to be transported...any migratory bird, any part, nest, or eggs of any such bird...included in the terms of conventions between the United States and (Canada)...the United Mexican States...and the... Government of Japan”.
BRAW absolutely supports this law. It is therefore illegal to destroy any nest, eggs or young of any

songbird except in the following situations approved by Ms. Andrea Kirk, Permits Chief, Migratory Birds, USFWS Region 3, Ft. Snelling, MN 55111 on Dec. 27, 2006. Ms. Kirk has determined that nests and/or eggs of any songbird are inactive in the following situations and can therefore be destroyed. For specific removal criteria, see **Nest, Egg and Chick Removal**, on Pg. 12.

It is our experience that when empty, partial or complete nests, or nests with unhatched eggs are left in the box, it “blocks” nesting attempts from individual hens that started the nest



Rick Perfile

or from new hens. Although we do not know which “type of bluebird” is being blocked, our data indicate that removal of the nests using the procedure listed above, leads to a new nest being built and/or clutch of eggs laid by a bluebird, within one or two weeks in most boxes, when this procedure is followed in the months of April through June. Leaving the nests or eggs in place delays further nest attempts by up to 6 weeks.

On December 2, 2006, the BRAW Board voted 12 to 0 to establish the following policy: “No bluebird monitor’s data will be accepted for seasonal reporting if they are known to destroy active songbird nests”.

Monitors are expected to follow the criteria for inactive nests approved by the USFWS on Dec. 27, 2006.

7) Problems encountered while monitoring boxes

a) Nest boxes occupied by other bird species.

Swallows, wrens & chickadees are “good guys”, i.e., songbirds. They should be treated with respect as described above. The best technique

to keep song birds other than bluebirds out of your boxes is to put them in habitat preferred by bluebirds, not other species.

Swallows prefer habitat with water over the drier, upland habitat preferred by bluebirds. Keeping boxes away from water (including marshland) will increase the chances of attracting bluebirds to them.

Wrens love short & dense, brushy vegetation with shading. Keep boxes 100’ away from such vegetation and usually only a dummy nest is built. It is best to move the box another 50-100’ away from the dense vegetation if nesting is attempted.

Chickadees are the least likely to occupy a bluebird house. They prefer edges of conifer woods and shaded nesting habitat. Keeping boxes 100+ feet away from such habitats will usually eliminate their nest attempts. Sometimes they will occupy a box in the open, far away from woods. But it is rare that these nests are successful. There really is nothing you can do to prevent these occupations. But three weeks after you experience a completed clutch without hatching, touch it to see if the eggs are being incubated (chickadees cover their eggs when they leave the nest, so carefully remove the hair covering them to “feel” the eggs). If they are cold to the touch, you can legally remove the eggs and nest. Our experience is that chickadees are the least successful of all the songbirds attempting to occupy our bluebird houses and they are most likely to be ousted by bluebirds.

Most monitors struggle with House Sparrow problems. We have tried a variety of techniques to keep sparrows out of boxes but nothing worked long term. Our approaches included using PVC and K-Box models—they failed. We have tried sparrow “spooks” of tinsel & pin-wheels, plastic covers over entrance holes and fishing line hung from the roof in front of the box openings. They failed. We have tried waiting until the hens lay eggs, removing the nests and crushing the eggs on the platform. That failed.

The best approach for sparrows is to stay away from properties heavily infested with them (cattle farms and homes which feed millet and cracked corn). If that fails, use Van Ert traps to

remove sparrows (details on Pg. 12).

b) Wet nests.

Rarely do nests get wet in boxes. If they do, the most common reason is a “leaky box”. The first consideration, therefore, is to repair the box by replacing boards, tightening them or caulking leaks. Sometimes, under extraordinary conditions, winds will blow so strongly, that an otherwise “water-tight” box will “take on water” and produce a wet nest.

Songbird hens, including the bluebird, incubate their eggs at about 97F. A wet nest quickly drops the egg temperature below this level, causing arrested development. Wet nests also cause abandonment of nests prior to egg laying. If there are young in the nest, especially less than a week old, they will quickly die of hypothermia from a wet nest, especially in cold weather.

The bottom line is, replace all wet nests with dry material. It is best to begin the season with a small sack of dried vegetation, good enough for making up to 6 nests.

All too often, when you experience finding a wet nest, all other vegetation around the box is wet. “Plan ahead” is a good policy when it comes to wet nests. Once the hen completes a nest, she will tolerate any kind of cup-shaped vegetation that might be available to make a “humanly-constructed” nest.

Preferred materials, however, include white-pine needles and any dead but soft, short-leaved grasses.

All the monitor has to do is form a cup-shaped nest approximating the dimensions of the nest in the box. Remove the eggs or chicks from the wet nest and place them in the dry nest. Put the dry nest with eggs or chicks, back into the box and pat it down a bit to approximate the size & shape of the previous nest. Do not worry about this part of the process, however, as the hen will quickly arrange the new nest to her liking. It should be noted that it is common for hens to use damp grasses while building nests. These dry out quickly. Don’t change wet nests unless they have eggs or chicks in them.

c) Starving chicks in the box.

The first step is to identify starving

chicks. If there is a dead chick in the nest already, that is usually a good sign that other chicks in the nest are stressed as well. It is more likely, however, that you will discover starving chicks by finding them largely unresponsive to your typical pishing/kissing/whistling noises. In addi-



Leif Marking

tion, if no adults are seen around the nest box, it is likely that one or both parents are dead or have abandoned the chicks. The chicks must be lively enough that they can still “gape”. Otherwise, fostering them will not work. If it is cold weather, wrap the young in tissue or toweling that will keep them warm. If chicks are cold to the touch, they should be placed in a cloth and warmed with your breath. This approach might be necessary until you can find a nest where the body temperature of the hen and chicks can raise the temperature naturally.

You should try to locate a nest with chicks in it that are somewhat younger than the age of the chicks that are starving. This strategy is important because the starving young are retarded in their physical development and after being adopted by the new parents will grow at about the same rate as the younger chicks.

Often, however, trails are so small that not many choices are available to use for adoptive nests. I have successfully fostered chicks into nests in which the occupant chicks were 6 days older than the adopted chick(s). This places a hardship on the parents, however, as they have to cope with juveniles outside the box and a chick(s) inside the box. But the technique will still work.

Another rule of thumb is to put no more chicks into the adoptive nest than will total 5 or 6 (6 only if absolutely necessary). Two healthy adult birds can raise 5 chicks in most cases, but coping

with 6 is stressful and can lead to the loss of the adoptive chick.

d) Critters invading the box.

i. Blackflies.

See treatment approaches on Pg. 12.

ii. Blowflies.

Blowfly larvae are gray-brown and about ½” long and are usually not very active when you find them in the nests. It is true that blowflies are ectoparasites on nestlings, attaching to the abdomens for nourishment. Typically, these “feedings” occur at night and the larvae return to the safety of the nest during the day.

Use Permethrin-10 spray on nests prior to egg laying or by using a glass cover after eggs are laid (see Pg. 13). Some researchers have suggested that the survival of House Sparrow chicks was reduced after blowfly parasitism. If that is the case, bluebird and other cavity nesting bluebird chicks might be surviving but weakened by blowflies and have a higher mortality after fledging. Treatment of nests with Permethrin-10 should kill the blowflies and prevent any deleterious effects due to these ectoparasites.

iii. Ants.

Ants are rarely a problem in nest boxes, although they have been known to attack, kill, and devour newly hatched nestlings on occasion. They may even attack and kill the young birds by entering the eggs as soon as the shells are cracked in the hatching process. (Zeleny 1976).

To control ants use Permethrin-10 spray as per the use with black flies and blowflies. Another approach is to use an “ant & roach” powder that can be purchased from any lawn & garden supply store. To apply, lift the nest with a paint scraper and spread dust over the surface of the nest platform. Insecticide dusts are contact poisons, so do not aspirate it into the area of chicks and adults or they will be able to breathe it. Using these application techniques, we have noticed no harmful effects to nesting birds. Wear a rubber glove for application of Permethrin-10 or insecticide powders.

iv. Mites

BRAW monitors have recorded no known fatalities from mites. In fact, it is rare that they occur in numbers large

enough to be detectable by humans. But sometimes, they overrun a nest and must be dealt with when removing the old nest. It is best to use gloves as they are “creepy crawlers” of the worst kind. They do not harm humans (and apparently the birds in the box), but they are uncomfortable if they get on your skin. Just rub them off and try to “dust out” the box as best you can so the next brood will not start with a bad mite infestation. It is our experience that mites are more common in Tree Swallows than other songbirds.

v. Wasps

Rarely, wasps attach inside the nest box but more commonly they attach underneath it. It is always possible to get stung by them, so caution should be used when removing the nest. To prevent their further attachment to the same site, spread vasoline or bar soap over the place the nest stalk attached to the box. Peterson nest boxes are particularly prone to wasp infestation under the floor.

e) Climatic Effects.

In northern latitudes, cold has proven to be the most limiting factor during the reproductive season, much more so than heat (as reported by bluebird monitors across the state).

The most sophisticated temperature studies done by BRAW members are those by Marking, Craig & Koperski (2006, 2008) and other members of the Brice Prairie Conservation Association (BPCA). In two studies on temperatures in nest boxes, they made these important observations: 1) east facing nest boxes showed increased temperatures as they were hit by the morning sun (this temperature spike supposedly explains in part why bluebird production in northern latitudes increases when boxes are placed in Northeast, East or Southeast-facing directions [Dhondt & Phillips]) 2) Non-vented boxes are warmer in spring and cooler in summer than vented boxes. Eliminating vented nest boxes during springtime has led to improved bluebird production by BPCA and 3) painting nest boxes dark colors increases heat stress in bluebird chicks in the months of July and August and should be avoided. Painting is not necessary, but if it must be done, light colors should be used.



Jack Bartholmai

The Well-Equipped Monitor.

The following suggestions are only guidelines and include materials for repairing nest boxes, something that you might have to confront. It all starts with a container of some kind. You can use a small bucket, or use a knap-sack, a fanny pack or fishing tackle box.

Below is a list of items that can be useful when you monitor nest boxes:

- 1) Form 22, & pencil (Download form at www.braw.org)
- 2) Clipboard or notebook for data forms (I prefer a three-ring binder)
- 3) Flat paint scraper to remove old nests; plastic sack for old nests
- 4) Brush to clean out nest box
- 5) Pilers & screwdriver
- 6) Hammer & caulking for repairs
- 7) Fence post driver and cordless drill for putting in posts/ attaching boxes
- 8) Permethrin-10 solution in an aspirator bottle for controlling, blowflies, ants & black flies (when present) and/or ant & roach powder.

So Why Else Should We Monitor Bluebird Boxes?

Few persons in the world have the chance to experience the wonder and mystery of the reproductive development of a wild creature. But nest box monitors do. This is a sacred experience that should be shared with as many people as possible.

It is likely that in this modern age of technological marvels, fewer and fewer children have the chance to “experi-

ence nature”. Take adults & especially children with you on your monitoring trips. Explain to them the wonders that you see each time you go out on your trail.

Good luck finding, raising and fledging “the blues” and other cavity nesting songbirds.

LITERATURE CITED

- Berger, C., K. Kridler, and J. Griggs. 2001. *The Bluebird Monitor's Guide to Bluebirds and Small Cavity Nesters*. Harper Collins Publishers, Inc., New York, NY.
[braw.org](http://www.braw.org) / BRAW Articles
- Close, W. *Bluebird Houses: Round or oval entrance holes?*
- Marking, L.L., F. Craig & C.A. Koperski. 2006. Effects of shade, insulation and Heat reflective Materials on Temperatures of Bluebird Nest Boxes. *Wisconsin Bluebird*, Vol. 21, #4.
- Marking, L.L., F. Craig & C.A. Koperski. 2008. The Effects of shade and Ventilation Combinations to Alleviate Temperature Problems in Bluebird Houses. *Wisconsin Bluebird*, Vol. 23, #1.
- Davis, W.H. and P. Roca. 1995. *Bluebirds and Their Survival*. The University of Kentucky Press, Lexington.
- Dhondt, A.A. & T. Phillips. 2001. A Question of Preference: Does the orientation of a nest box affect the breeding success of cavity-nesting songbirds? *Birdscope from Cornell Laboratory of Ornithology*. Spring, Vol. 15, #2.
- Ehrlich, P.R., D.S. Dobkin, and D. Wheye. 1988. *The Birder's Handbook*. Simon & Schuster, Inc., New York, NY.
- Gill, F.B. 2007. *Ornithology, 3rd Edition*. W.H. Freeman, Co., New York, N. Y.
- Gowaty, P.A. and J.H. Plissner. 1998. *Eastern Bluebird (Sialia sialis)*. In *The Birds of North America*, No. 381 Poole and F. Gill, eds.). The Birds of North America, Inc., Philadelphia.
- Kight, Caitlin R., Margaret S. Saha and John P. Swaddle. 2012. Anthropogenic noise is associated with reductions in the productivity of breeding Eastern Bluebirds (*Sialia sialis*). *Ecological Applications* 22:1989-1996.
- Zeleny, L. *The Bluebird: How You Can Help its Fight for Survival*. 1978. Indiana University Press, Bloomington.
- Dr. Kent Hall of Stevens Point was instrumental in providing much of the contents of this guide. He is a former Vice-President of BRAW.

BRAW EZ Summary Form

Use this card to report your nest box results for the season.
DEADLINE SEPTEMBER 30

_____ No. of boxes* _____ Boxes used by Bluebirds*
 _____ Bluebird eggs laid _____ Bluebird eggs hatched
 _____ Bluebirds fledged * _____ Tree Swallows fledged
 _____ Chickadees fledged _____ House Wrens fledged

"I did not disturb any Chickadee, Tree Swallow or House Wren nests."

*County _____
 Year: _____
 *Name _____
 Address _____
 City _____ State _____ Zip _____
 *Phone (_____) - _____
 email: _____

*= Required data. Please provide any other data or information.
 Comments: _____

EZ Summary data can be emailed to wibluebirdtaentry@gmail.com
 Thank You!

Use the Van Ert Trap to solve Your House Sparrow Problems

Figure1 – Installation is quick and simple provided there is a screw intact.



Install the trap and set it per instructions. Watch to see if you catch a House Sparrow or return to the box after a short time to check to see if the trap was sprung. You don't want to trap a bluebird and leave it trapped. To check caught bird use a large, clear plastic bag over the box and slightly open the side. The trapped bird will fly to the top of the bag for you to see what you have. Release bluebirds and remove House Sparrows.



Figure 2– The visible red bulls eye invariably suggests a trapped sparrow.

Nest Guide to Cavity Nesters

by Patrick Ready/BRAW

Eastern Bluebird

Fine or coarse grasses, pine needles, lined with fine grasses.



Tree Swallow

Similar to bluebirds, coarser grasses & straw, lined with feathers when eggs are laid.



Black-capped Chickadee

Moss, fine grass, lined with animal hair.



House Wren

Sticks and twigs jammed in tight. Lined with a small amount of fine grass and hair. Often builds dummy nest with a few sticks but without lined cup.



House Sparrow

grass, straw, feathers, paper, plastic, etc. and they usually swirl the grass upward to fill the box, then tunnel down in. Sometimes when a nest is first started it may be hard to tell what species is nesting. Wait a day or two to see how the nest develops. Feathers and wrappers early on with some grass pieces are definite signs of House Sparrows.



Above: Peterson box filled with straw, grass, and garbage indicate a House Sparrow nest.

Middle: Eggs-white or grey with brown specs

Left: Beginning nest. Similar to bluebird and tree swallow but note chicken feathers and debris = signs of a House Sparrow nest.

Species Identification of cavity nesters

Male & female Eastern Bluebird



Fledgling Eastern Bluebird

Female & male Tree Swallow.



Black-capped Chickadee, sexes similar.



House Wren, sexes similar.

BRAW management practices that help improve Eastern Bluebird production

<p>Location, Location, Location:</p> <ol style="list-style-type: none"> 1) Need a territorial forage area of 1-3 acres of predominantly open habitat 2) Ideal sites: short, sparse grass with interspersed trees: cemeteries, golf courses, parks, business parks, bike trails, RR tracks. Call DIGGERS HOTLINE before installing boxes in unfamiliar areas. 3) Boxes should be totally exposed to sunlight from sunrise until noon; thereafter, shading is permissible 4) Perch sites: <ol style="list-style-type: none"> a) One or more trees (10' ideal) within 100' (preferably closer) to the front or to one side of nest box (most hunting starts on a perch and these trees are vital for use as survival perches when chicks first fledge) b) Fences (barbed, electric, wooden) c) Electrical wires (no more than 30' high preferred), clothes lines 5) Noisy sites okay (interstates, other roadways, railroads, temporary air shows, church picnics) 6) Roadways with limited traffic can be ideal nest box sites and adults and young chicks are rarely killed by traffic. 	<p>Nest, Egg & Chick Removal for bluebirds, chickadees, Tree Swallows (1,2,3,4) and House Wrens (4): Procedures approved by USFWS in Dec., 2006</p> <ol style="list-style-type: none"> 1) Partial or complete nests w/o eggs: 1st week; 2nd, 3rd weeks no change, then remove; restart week count if more building occurs; if wet, remove, replace with dry, fine grass or pine needles 2) touch eggs each week; if they are warm, they are being incubated; if they then turn cold, they have been abandoned and are dead; to test your judgment, remove a single egg and crack it open. If the egg is viable (has a moving embryo), leave the remaining eggs—but if the embryo does not move (= dead) or the egg is empty, remove cold eggs and nest. <i>(Always use caution as some hens delay brooding for up to a week.)</i> 3) It is also possible for dead eggs to be incubated well after they should have hatched (up to four weeks), and are warm to the touch. Leaving eggs in a nest this long simply “robs” the nesting pair of precious time in the season when they could be rebuilding a productive nest. To prevent this problem, estimate the date for the last egg being laid (one egg is laid/day). Add 19 days to that date (14 for incubation; 5 for a delay in incubation) and when the monitoring date hits the 19 days or beyond, remove a single egg and repeat the procedure in #2). 4) Chicks starving/lethargic: foster into nests with chicks of similar age, + or - 2 days [place with slightly younger, if possible]; 85% reared by adoptive parents in a 4-year study by the ALAS in central WI 5) House Wrens Only: If a partial nest of sticks is in your nest box the 1st week, remove them; the 2nd week remove them and tape the opening. In two weeks, open the box and repeat. The 2nd taping should be left until the end of the season because no other species can nest in the box in the territory of a wren or you can choose to allow the wren to complete its nesting. If egg cup or eggs are found at any time, you should allow the natural cycle to continue.
<p>Relocation:</p> <ol style="list-style-type: none"> 1) Change the nest box position if there has been no bluebird nesting attempt in a season OR 2) Change by the end of the following April (75-90% of nest boxes have been occupied by bluebirds by then); if no nesting has occurred by the end of April your 2nd nesting season, it is sign that your site is unappealing to bluebirds. But moving them to better nest sites still gives you a 50:50 chance of occupancy for the season. 	<p>Common Predators of Bluebirds: Raccoons, House Sparrows Black Flies and Mice:</p> <ol style="list-style-type: none"> 1) Do not put boxes on wooden fence or electrical posts. The cheapest and most convenient mounting system uses 3/4" electrical conduit. Cut 10' conduit to 6'-8" lengths. Flatten 4" at end and bury 18" of conduit. To the remaining 5' conduit attach two 3/4" clamps and screw to box. Two 3/4" pieces can be joined with a coupler to make a 6'-8" post. 2) Raccoons: Leif Marking and assistants videotaped raccoons climbing fence posts covered with PVC tubing. Previously, it was thought that such protected posts could not be climbed by them. It was also thought that one could detect raccoon predation raids by nesting materials being pulled from boxes. The Marking team found that raccoons could remove eggs and pop them into their mouths without removing nesting materials. To prevent raids of your nest boxes by raccoons, three preventive measures are suggested: A) Use steel wool or a wire brush to smooth off oxidized PVC and/or B) smear car wax paste on the post. C) Noel Guard on front of box (see page 19) 3) House Sparrows are introduced species from Europe. They have no legal protection from the USFWS in North America. They have a strong, seed crushing beak that easily out-competes the slender/weaker insect-eating beak of other songbirds. The best way to prevent these pests from occupying your nest boxes is to keep them away from livestock (especially cattle) or homes with feeders using millet and/or cracked corn as these locations attract large numbers.
<p>Box Style/Dimensions:</p> <ol style="list-style-type: none"> 1) In “the wild”, bluebirds prefer to occupy old woodpecker holes that are not usually very large or deep 2) Shallow, narrow boxes work best: <ol style="list-style-type: none"> a) 4-5" below the bottom of the hole as maximum depth b) 4 x 4", 4 x 5" nesting platform (inside dimensions) 3) Keep vents closed until June 1 to prevent windchill from killing eggs and/or chicks. High temperatures can kill chicks in nest boxes. But cold weather has still proven to be more damaging than heat. Since it is likely that the changing climate assures high summer temperatures in the future, we recommend monitors consider making their boxes “convertible” by dropping side doors in the summer and replacing them at the end of the season. For Peterson boxes, holes can be drilled at the top of one side and a piece of “lathe board” placed over them until June 1. A single or pair of screws can be used to seal the openings during spring. The main thing to do here is to produce air circulation to prevent heat buildup as in an attic. On the other hand, in the south-western part of the state where black flies are a problem, screens should be placed over the openings to prevent ease of black fly entry. 4) Oval hole small enough to keep out starlings & cowbirds 5) Use a predator guard on your mounting post or make the mounting post your predator guard (3/4" electrical conduit preferred) and keep the post waxed with car wax. A Noel Guard attached to the front of the box can also deter coons from getting eggs or chicks. 	
<p>Spacing:</p> <ol style="list-style-type: none"> 1) Space no closer than 100-200 yards (1-3 acre territories needed); encourages Tree Swallow occupation if boxes are placed closer than this 2) Pairing reduces bluebird and increases swallow production/box 	

But these pests can fly up to ½ mile to occupy a box, so considerable habitat is lost to nest boxes unless another alternate is used. And the best alternative is a **Van Ert trap** (cost is about \$10 ea. Pg. 18). Van Ert traps are easy to insert and highly effective when used properly. (see Pg. 9) They should be set only when the sparrow is building a nest or has already constructed one. Then, all nesting materials should be removed from the box (including eggs). Usually, the male is trapped and that is a good thing because he is the “enticer” of the female. Trapping a female is not as effective as the male will just attract another female. Rarely, both are trapped together. To dispose of the sparrow, put a clear, plastic bag (held tight at the bottom) over the nest box. Open the door and the sparrow flutters out and can be pinned against the side of the box and then disposed of. In 60-75% of the time, only one trapping is necessary to clear up the nest box for protected songbirds. The major problem faced by trapping sparrows is how long to leave the traps in place. You can use two approaches: A) Set trap and return after monitoring the rest of your boxes or B) Set trap and return the next day. By that time, the sparrows are dead, but if you have trapped a swallow or bluebird, they will still be alive and can be released unharmed. Leaving traps in nest boxes rarely leads to the deaths of protected songbirds, IF the trap is left unmonitored **no longer** than 12 hours.

4) Black flies are a menace like no other to cavity nesting songbirds. In Wisconsin, blackflies are limited mainly to the southwestern, driftless areas of the state. The counties there have many slow-moving but low-pollution streams that are ideal for production of black flies. Female black flies are the real culprit of this insect. Like female mosquitoes, they are attracted by CO2 given off by incubating hens or immobile chicks and bite them for a blood meal. Females are driven off their eggs by the persistent biting of black flies but chicks can't get away from black flies and are killed by dozens of black fly bites. Anyone who finds a brood of chicks killed by black flies will not soon forget it. But we now have a way to prevent black flies. It's best to use Permethrin-10 poultry insecticide. Dilute it to 0.50% concentration and place it into an aspirator bottle such as a “Windex Bottle”. When you find black flies around your nest box (swarms hover like a large fruit fly) use this protocol to prevent the hen from abandoning the nest box and the death of the chicks: A) spray the opening and all cracks on the box, both inside and out B) if there are eggs in the nest, put a small, clear jar over the eggs and spray the nest thoroughly C) if there are chicks in the nest, make sure they are at least 3 days of age—mist thoroughly (spray does not harm the eyes) D) the 2nd week, spray the hole and cracks on the outside of the box only, plus the nest if the eggs have not hatched and spray the chicks for the 2nd and final time. If you recognize that black flies are being

attracted to your boxes, you can almost eliminate blackfly problems entirely, if you use these techniques.

5) Mice: Mice will often use a box to nest in. Cover your nose & mouth before removing mice nest as their feces can carry hantavirus bacteria which can be inhaled causing severe illness.

Woodpeckers

Woodpeckers can cause great destruction to nest boxes as they use them as roost-sites in fall, winter and early spring. Hairy Woodpeckers occupy boxes the most followed by Downy Woodpeckers. Leave the boxes open in the winter to keep woodpeckers out (even then, they sometimes do damage). We use wire to keep the doors open as “good Samaritans” walking past boxes completely open, sometimes close them as an act of good will during the winter. Wires can be unwrapped and boxes closed on March 15 to accommodate early arriving bluebirds. These wires can also be used to keep the side open for a week after the first bluebird brood has fledged to increase the likelihood that the bluebirds will produce a 2nd brood in the same box. This prevents competitive species from taking over the box while the adult bluebirds tend their first brood after fledging.

Another advantage to keeping the boxes open during the winter is that chickadees and House Sparrows do not use the boxes for roost sites during the winter. This approach levels the playing field for bluebirds coming to nest in the early weeks of the season.



Wiring boxes open to prevent woodpecker damage.

Direction of Opening:

- 1) Keep away from prevailing westerly winds (cools boxes)
- 2) Use the same direction for all boxes
- 3) Cornell University has determined that directing the opening of a nest box to the northeast, east, or southeast improves the fledging rate of Eastern Bluebirds in northern latitudes. Apparently, boxes pointed in that direction heat up more quickly in the mornings in cold weather but do not collect as much heat from a southern exposure in summer.



Female Bluebird



Male Bluebird



Immature fledgling

Fence post mounting system

Brice Prairie Conservation Association uses the "T" post method to mount NABS Style nest boxes on their trails in the LaCrosse area.

The "T" post method by Leif Marking



- Nest box lumber is 7/8" western cedar with rough side exterior
- 7 ft steel T-type fence post to accommodate the 1 1/2" PVC predator guard
- 5 ft section of 1-1/2" PVC cut partially for U-bolt-see photo (drain pipe or electrical conduit available in 10 ft sections)
- U-bolt that measures 5/16" x 2" x 3-1/4" available at Farm and Fleet

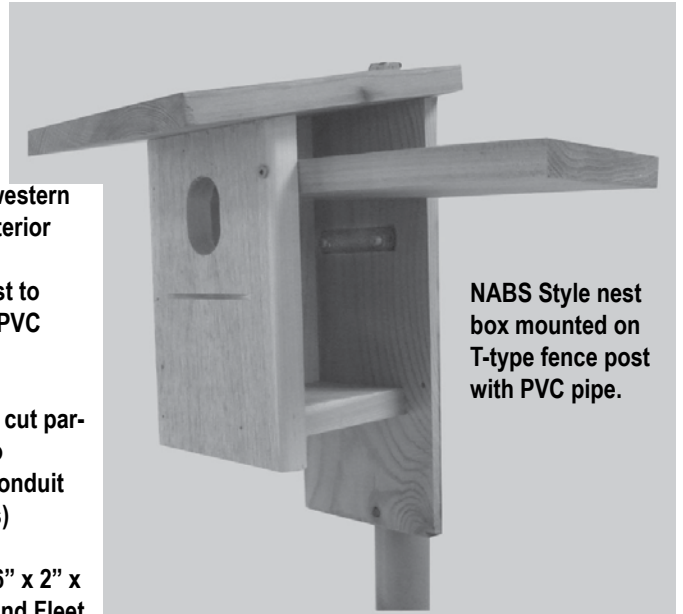

NABS Style nest box mounted on T-type fence post with PVC pipe.

These photos show how the single U-bolt through the slotted PVC fastens the predator guard and box to the steel T-type fence post. The common T-type fence post is cheaper, stabler, sturdier, and removable without mutilation.

3/4" Conduit Mounting System

By Bob Tamm

1. Using a standard 10 ft. section of 3/4" EMT conduit (available at Menard's, Home Depot, etc.), cut off about 2 - 2 1/2 ft. (hack saw) and discard.
2. Flatten tip of the 7 1/2 ft. or 8 ft. section with hammer or sledge. This makes it easier to pound pole into ground, and prevents it from turning.
3. Loosely attach 3/4" EMT conduit 2-hole straps to back of box using 3/4" deck screws. (Note: 3/4" deck screws are hard to find. I get mine at Menard's.)
4. Using post pounder, pound long conduit section into ground, allowing about 6 to 6 1/2 ft. above ground.
5. Slip box with straps onto conduit and adjust box for height. Then tighten screws.

Note: If you would like to use the entire 10 ft. section, try this: Measure two sections to 6'-8" and cut. You will have two left over 3'-4" sections, which will make a third 6'-8" section if you use a coupler. If you drive these sections about 14 inches into the ground, you will still have enough conduit above ground to mount a box on the 5 ft. above ground conduit. You then have three mounts from two 10 ft. sections.



NABS style Bluebird Box

Cedar, 7/8" lumber preferred.

8" wide for top

6" wide for back, front, sides & bottom

All angle cuts are 10 degrees

Roof is 7-1/2" wide x 10-1/2" long

Sides 9-7/8" long x 5" wide

Floor is 5" x 3-3/4"

Back & front 5-1/2" wide

Recommended Oval Hole Plan

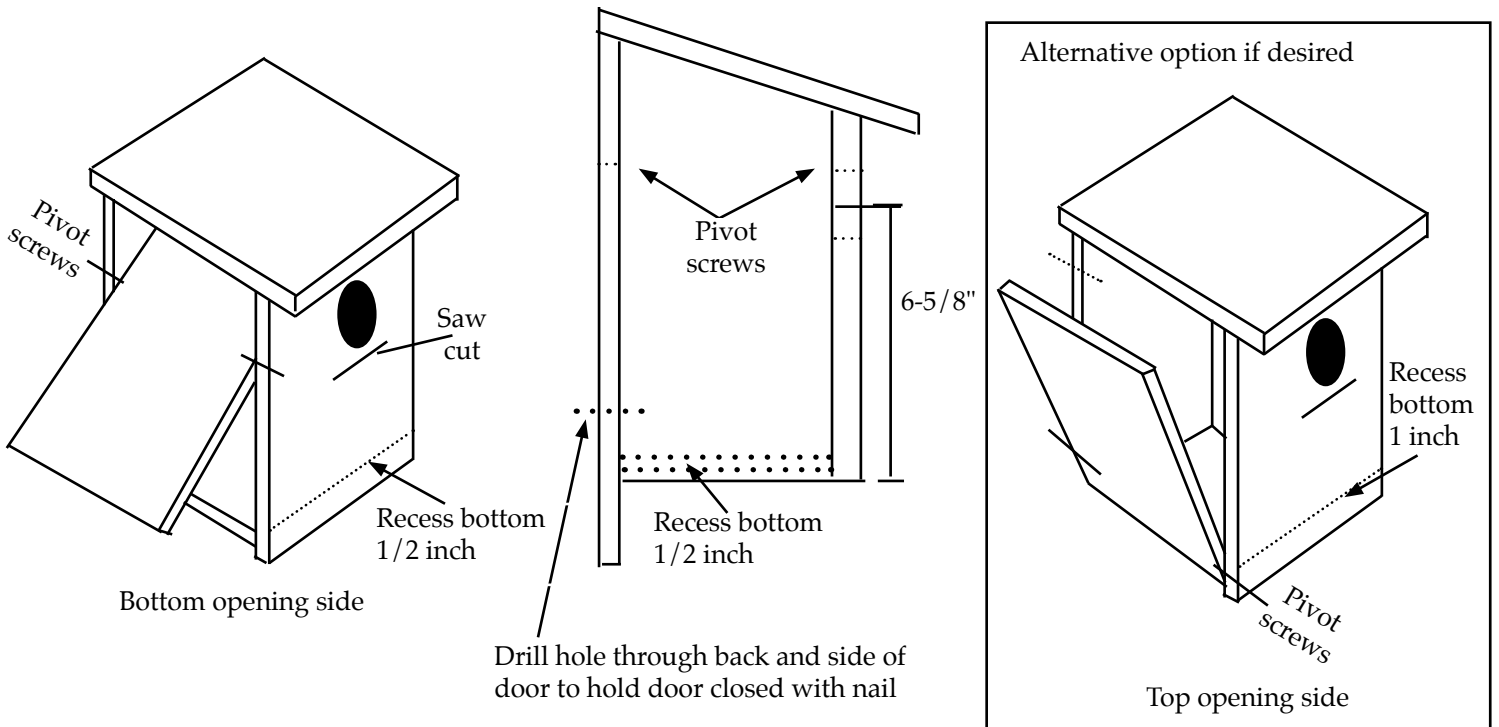
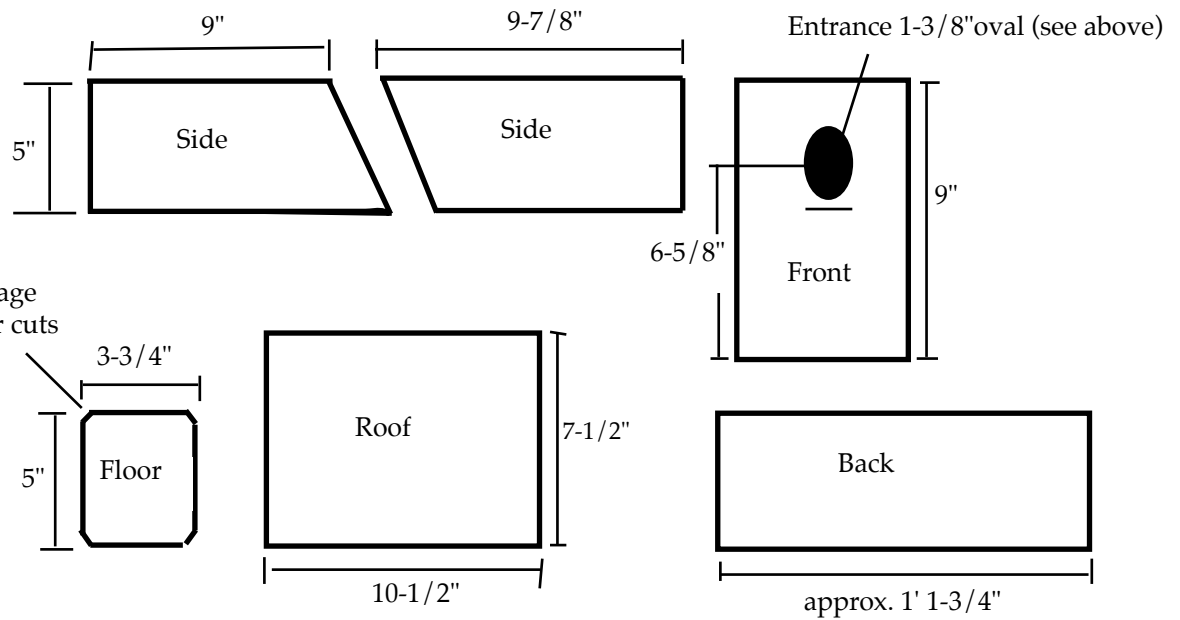
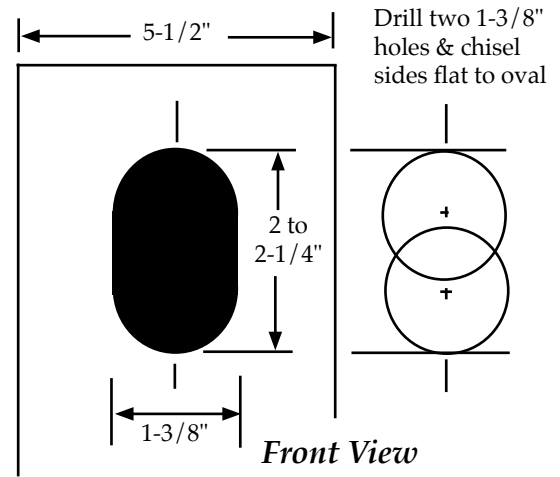

Peterson Nest Box (Unvented)

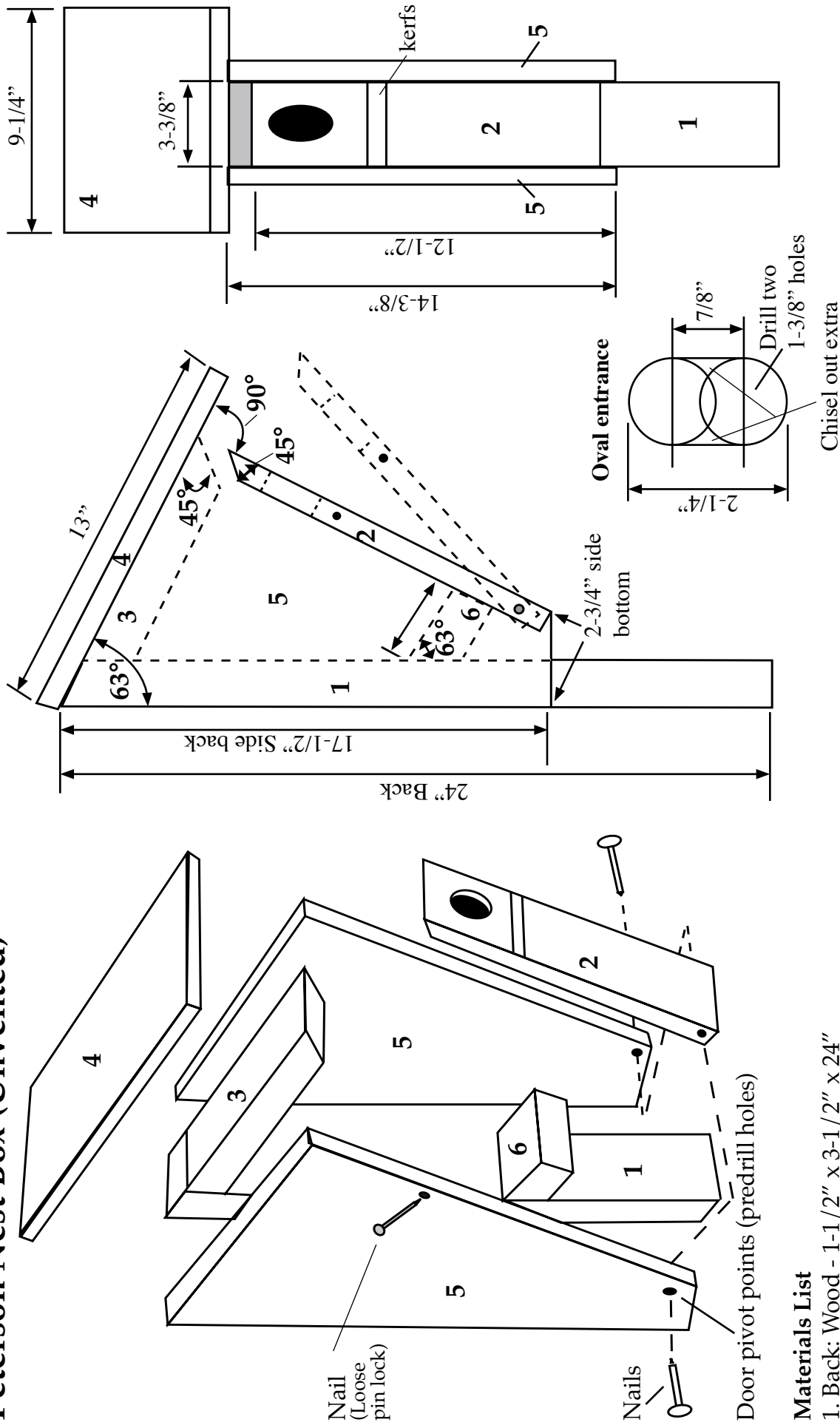

Materials List

1. Back: Wood - 1-1/2" x 3-1/2" x 24"
 2. Front: Wood - 3/4" x 3-3/8" x 12-1/2"
 3. Inner Top: Wood - 1-1/2" x 3-1/2" x 8-3/8"
 4. Top: Wood - 3/4" x 9-1/4" x 13"
 5. Sides: Lap Siding - 10-1/4" x 2-3/4" x 17-1/2" x 14-3/8"
Two sides are required.
 6. Bottom: Wood - 1-1/2" x 3-1/2" x 3"
- Nails: 26 required

The Peterson Box is more difficult to build but is an attractive design and makes an excellent bluebird nest box. Read the plans carefully before deciding to build this box. Make sure your skills are up to the task.

Because of the size and weight a "T" post mount is recommended.

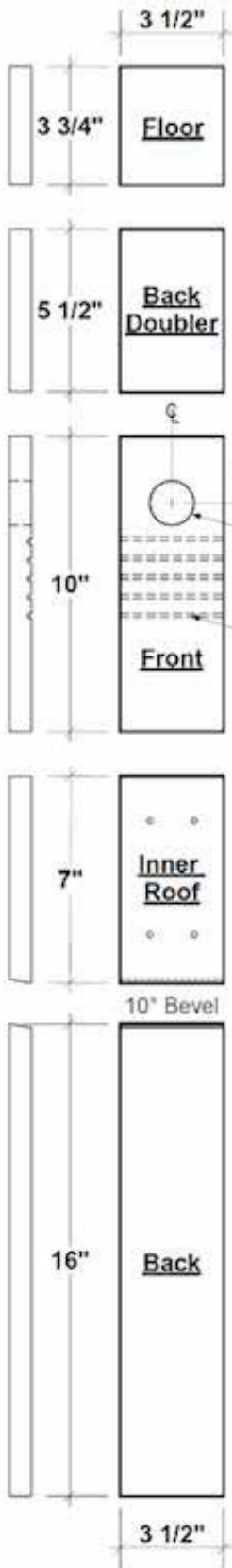

Note: Floor length may vary depending on thickness of wood used

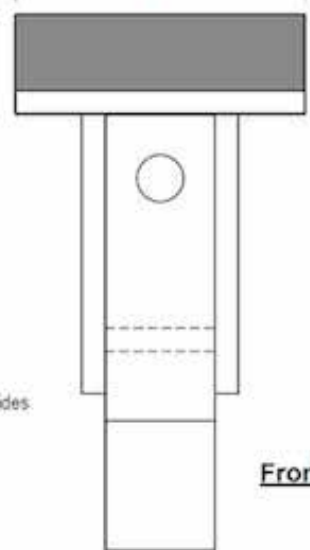
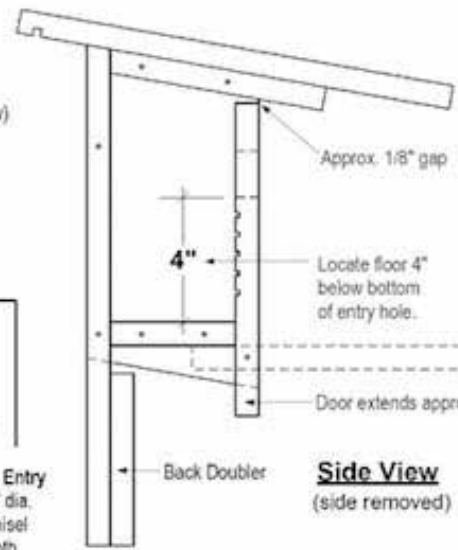
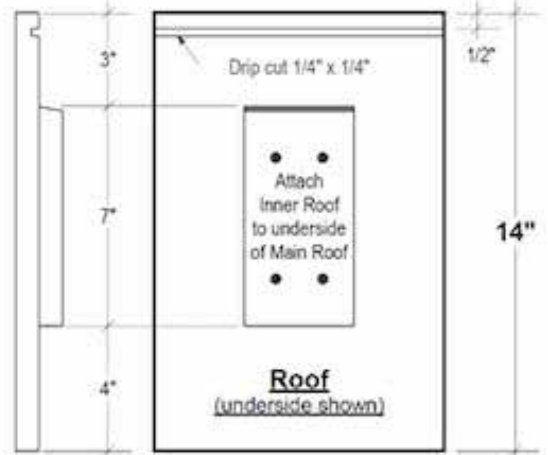

Optional Oval Entry Drill (2) 1 3/8" dia. holes and chisel sides smooth

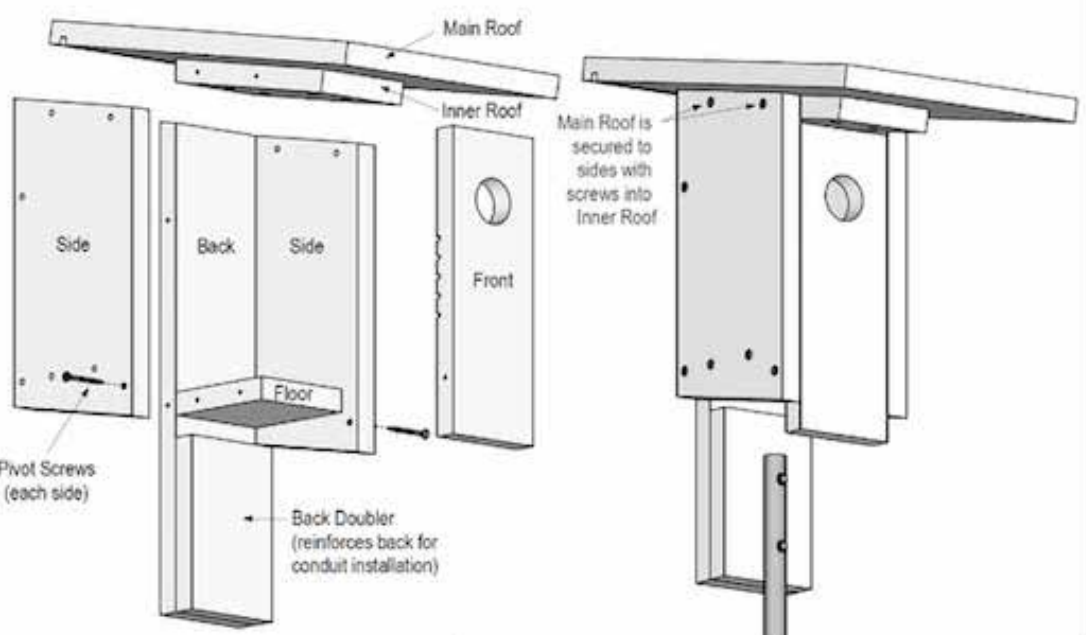

Quan	Material / Size	Component
44"	1 x 4 (3/4" x 3 1/2")	Front, Back, Floor, Inner Roof, Back Doubler
23"	1 x 6 (3/4" x 5 1/2")	Sides
14"	1 x 10 (3/4" x 9 1/4")	Roof

The Simple Nestbox
 Official nestbox of the Lafayette County Bluebird Society, Wisconsin
 designed by: Joe O'Halloran
 Drawn by: Fred Stille, Sr. Version 1.1, August 1, 2013 Page 1 of 1

Resources for bluebirders

County Coordinators are Ready to Help You

Once each year, *Wisconsin Bluebird* newsletter publishes a list of BRAW county coordinators to help the public locate their local bluebird program contact person. You can also find them listed on www.braw.org.

Some BRAW county coordinators conduct one or more late winter or spring bluebird workshops that are publicized locally. Most bluebird workshops are informational. Bluebird literature and data recording forms are on hand, and questions are answered.

Form 22, the weekly data recording form, is recommended to record your nest box information throughout the season. BRAW prints this form in the *Wisconsin Bluebird* newsletter throughout the year and it is on our website at www.braw.org.

Where to buy boxes or traps

The following vendors offer nest boxes and traps for sale. **Listing here does not imply endorsement or knowledge by BRAW, Inc. of quality of workmanship of these boxes, etc.** Prices and shipping costs are subject to change without notice.

Peterson Nest box
Morgan Woodworking
 304 Saint Rose Road
 Cuba City, WI 53807
 Ph. 608/744-8798
tcmorgan@mhtc.net

NABS style box & Simple box
Bluebird Nest Nature Center
 308 Main Street, Darlington, WI
 Open W-F 1-4 pm.

VanErt Sparrow traps
 Call: (641)-446-7416 or
 (515)-418-3787
www.vanerttraps.com

School and Youth Outreach

Want to help expand bluebird populations and promote environmental awareness among young people?

Consider contacting your local school principal about a program sponsored by BRAW. This program encourages school and youth groups to establish and monitor a bluebird trail. A trail can be as small as a few nest boxes or dozens. The School and Youth Outreach Committee will provide the BRAW Informational Packet (which you are now reading) to the interested group, which will help them get started.

A packet can be requested from Lowell Peterson, 1860 45th St., Somerset, WI 54025.

BRAW Membership Information

Wisconsin Bluebird Subscription and BRAW, Inc. Membership

Yes! I would like to renew my membership with the Bluebird Restoration Association of Wisconsin, Inc. and receive its newsletter *Wisconsin Bluebird*. Enclosed is my check/money order (do not send cash) made out to BRAW, Inc. for the following:

Subscription/Membership contribution:

- \$20 individual or Family Annual
- \$25 Contributing Annual
- \$100 Corporate Annual
- \$300 Life Membership

Print clearly

Name: _____

Address: _____

City: _____

State: _____ Zip Code: _____

Email Address: _____

Telephone: () _____

County of residence: _____

- \$15 to nest box construction with post & predator guard
 - \$100 for nest box trail
 - \$_____ for educational research (Master's thesis)
 - In addition to my membership contribution, I wish to contribute: \$_____
- (Contributions to BRAW are tax deductible)*

Check appropriate boxes:

- This is a renewal.
- This is a new subscription
- This is a GIFT subscription.

Enclosed please find my check \$ _____

Mail this membership/subscription request to:
 BRAW, Inc.
JP Lafouge
 9154 N. Fielding Rd.,
 Bayside, WI, 53217

You can also use PayPal or a credit card to renew your membership or make a contribution on the the BRAW website at www.braw.org

If you join during the year you will be on a quarterly membership and will not receive back issues.

Make a Noel Guard

Materials:

- 1 x 4" pine or cedar board
- Hardware cloth cut to 16"x6"
- 3 Screws 1-1/2" long

Tools:

- Staple Gun
- Drill
- Hammer (to pound staples down firm)
- Cut the wood to 4-1/2" length
- Drill a 1-1/2" entrance hole or an oval hole in the piece.

Starting on the bottom wrap the hardware cloth around the wood piece stapling it several times as you go. Drill 3 holes for screws in the wood piece for easy fastening to the box.

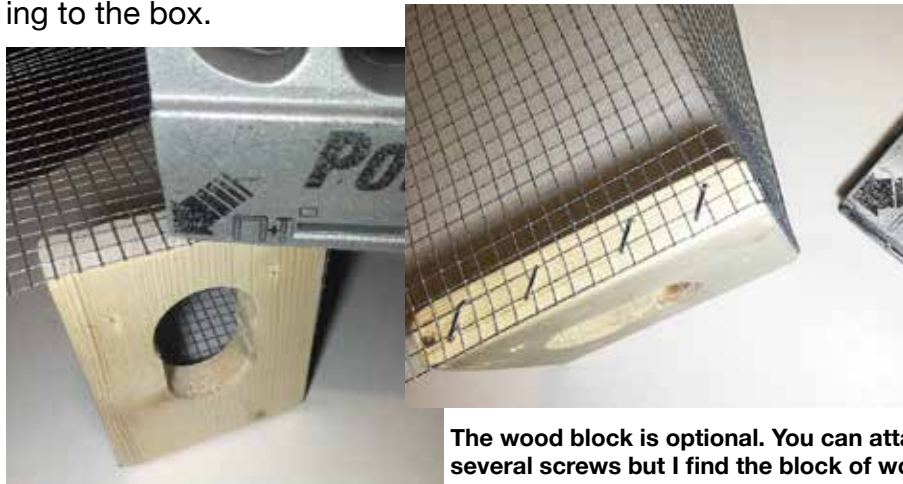
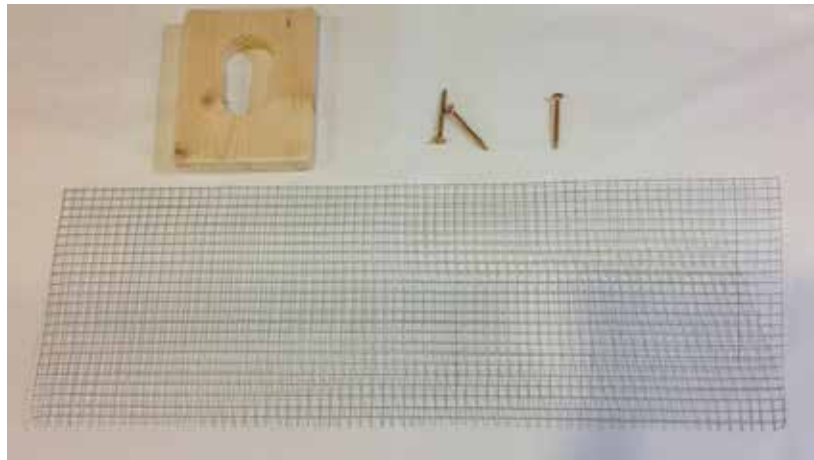

The wood block is optional. You can attach the wire directly to the front of the box with several screws but I find the block of wood makes a sturdier guard.

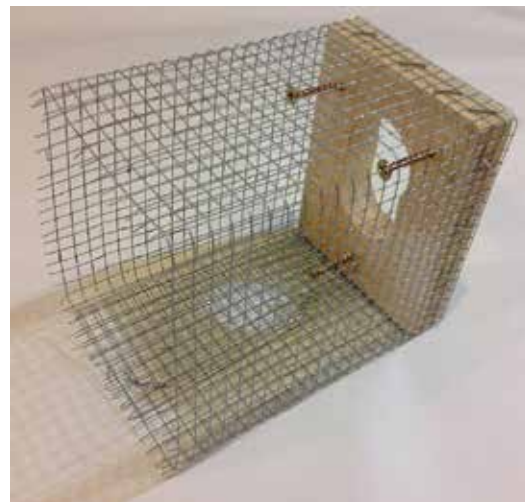

Make a Stove Pipe Coon Guard

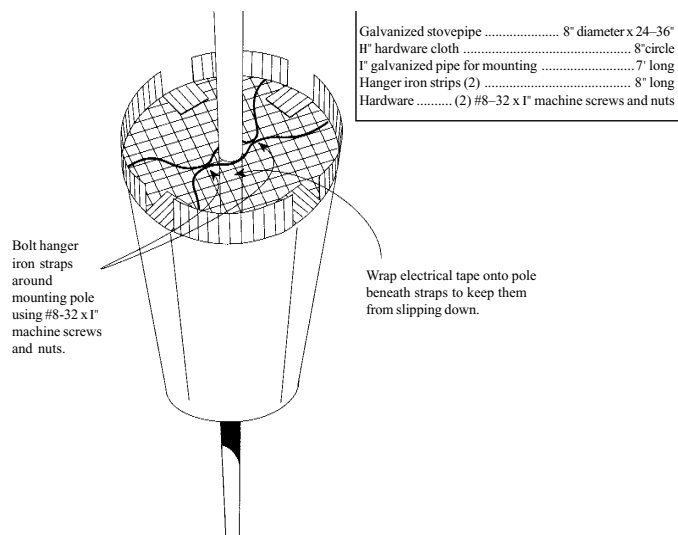

Using tin snips, shape hardware cloth into a circle. Make a small cut in the center so it will slip over the mounting pole. Bend the edges of the hardware cloth down and slide it snugly into the stovepipe. Cut four tabs on the top end of the stovepipe. Bend them inward, over the hardware cloth.

The complete plan above to make a Stove Pipe Guard is available on the website nestboxbuilder.com

Bluebird chick development

- first 14 days
by Jack Bartholmai

This series of images uses "wing development" as an aid in age estimation. Conditions such as food supply, temperature, number of siblings and other factors might alter the development time a +/- of at least one day for each image after day one. When chicks first hatch they are naked, eyes are closed and they barely can raise their head but they are able to open their mouths to be fed. Between the 5th and 10th day the chicks are most vulnerable to cold temperatures when the female stops brooding them. If they get too chilled and listless they won't raise their heads when the adult birds bring them food and may starve. Both adults may stop feeding them and abandon the nest if they don't respond. Monitoring should stop after the 12th day to prevent premature fledging. Normally by the 16th-18th day they are fledged.



All photos by Jack Bartholmai



Bluebird Restoration Association of Wisconsin

JP Lafouge, Memberships
9154 N. Fielding Rd.,
Bayside, WI, 53217
brawmembership@braw.org
www.braw.org

© BRAW

